

24

GOLD ALUMINIUM CHASSIS CONVERSION USER MANUAL

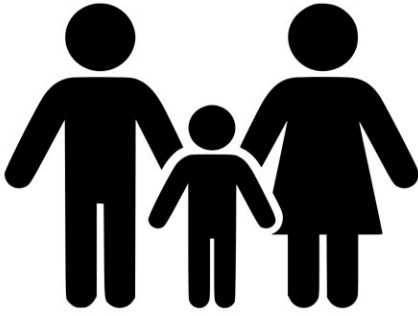



**Keep away from children.
This kit contains many small
parts and choking hazards**



**Please be advised that whilst
the resin 3D printed parts are
cured & safe, they should
never be swallowed!
(I hope this goes without saying!)**

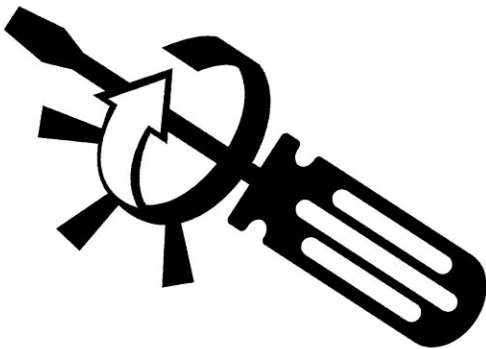

**Do not overtighten parts !
3D printed parts are more
vulnerable to overtightening.
Avoid excessive removal/
reattaching of screws.**



**The washing/ curing process of
the resin 3D printed parts may
leave some areas tacky or
sticky. Please use wet wipes
(industrial grade are best) on
these areas to help the issue**



**Not sure about something?
Ask us!
hello.nrcprojects@gmail.com
[Facebook.com/NRCProjects](https://www.facebook.com/NRCProjects)**



DRIVERS-
***0.9MM HEX**
***1.5MM HEX**
***PH 0 SIZE PHILLIPS**
***APPROX 0.5MM SLOT**
FLAT HEAD



PIN VISE/PIN DRILL
DRILL BITS- 1.5MM
(YOU MAY NOT NEED TO USE
THIS TOOL IF YOUR ROD ENDS
MOVE FREELY)

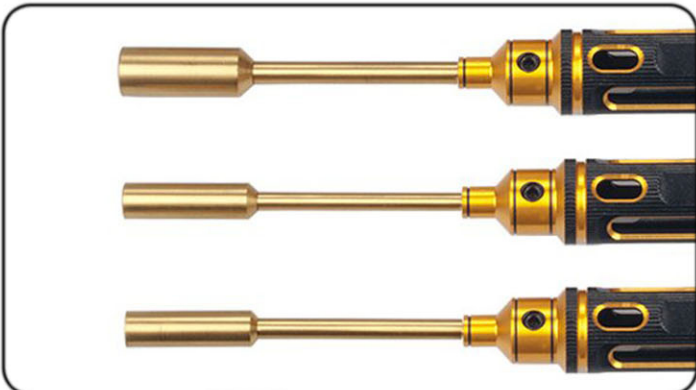

M2 NUT DRIVER-4MM



SMALL PLIERS



WET WIPES
(SOME RESIN 3D PRINTED PARTS MAY
HAVE AREAS THAT ARE TACKY/STICKY TO
TOUCH. FIRMLY WIPING WITH WET WIPES
HELPS THIS ISSUE)

FRONT
CHASSIS
BRACE

M2x30MM

M2x12MM

M2 NYLON NUT

LONG FRONT
BODY POST

M2x10MM
GRUB SCREW
V2. STEERING
BELLCRANK

M2x5MM
COUNTERSUNK
SCREW

CHASSIS
SIDES

M2x6MM

MAIN CHASSIS

M2x10MM

V2. REAR
BULKHEAD

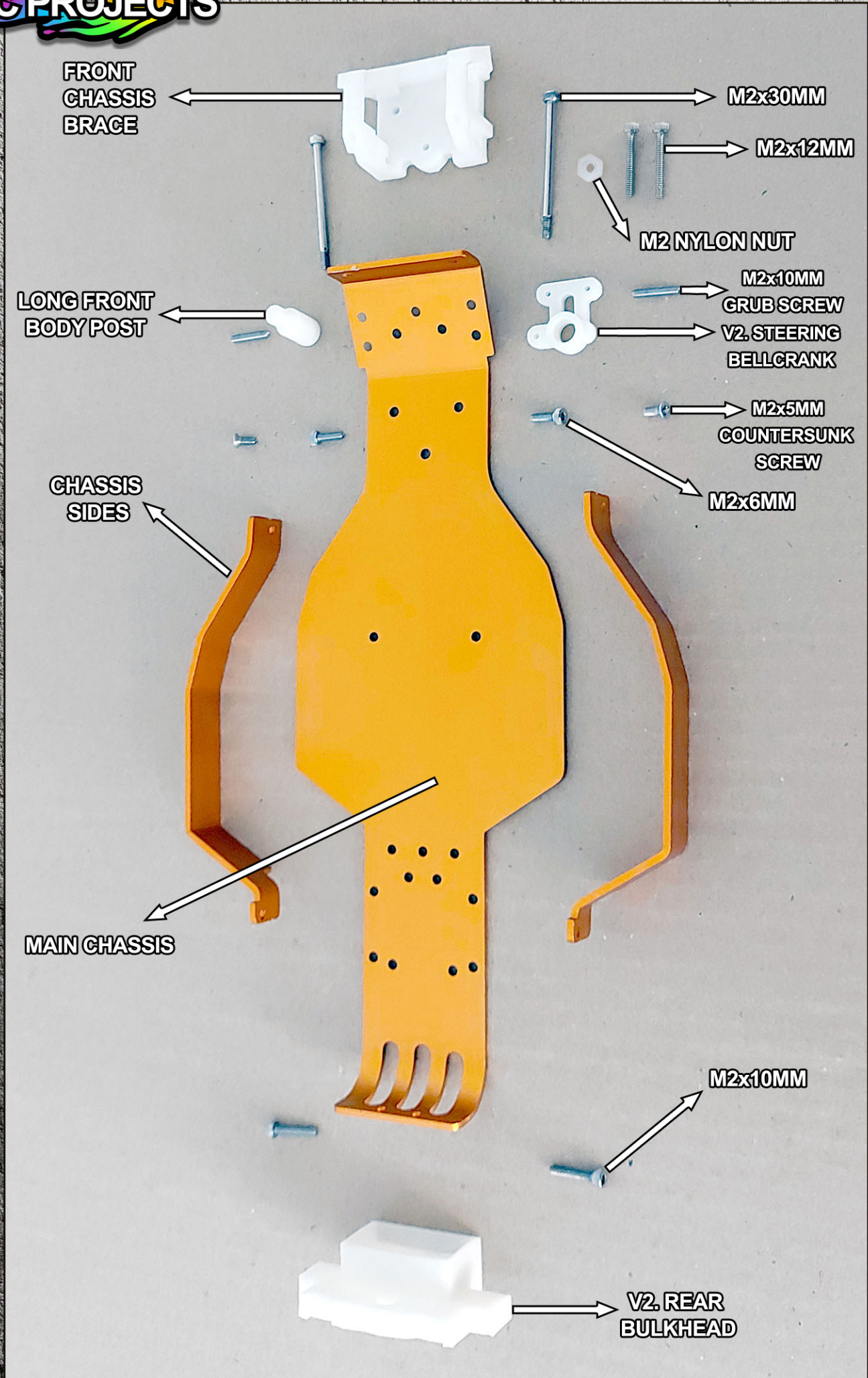

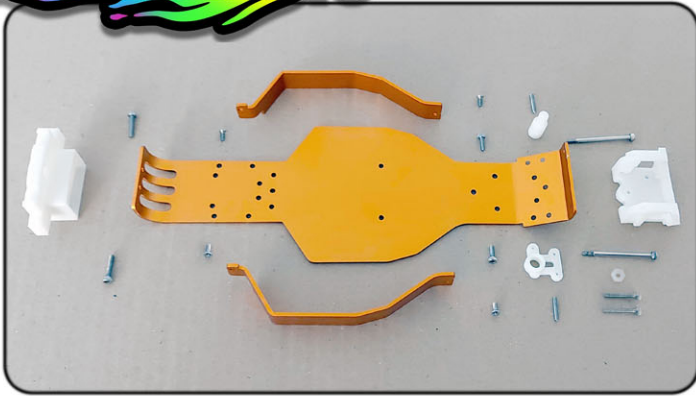

FAMILIARISE WITH CONVERSION KIT CONTENTS.

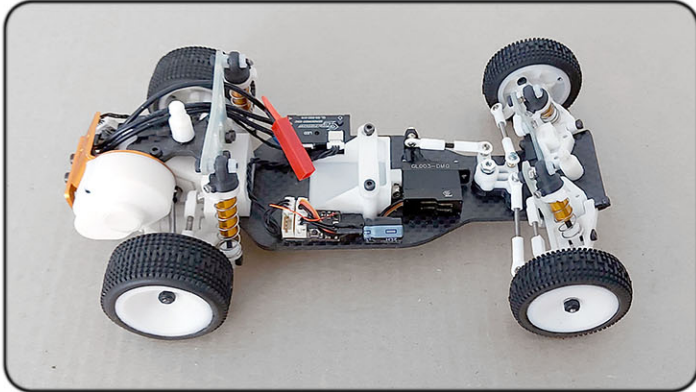

**NRC-24:
READY FOR CONVERSION!**

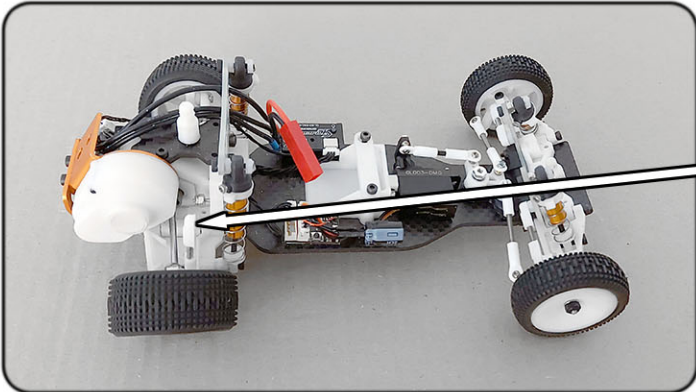

REMOVE REAR CAMBER LINKS FROM REAR BULKHEAD

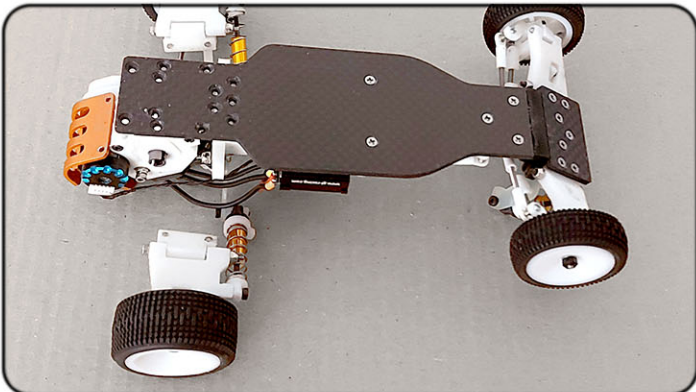

REMOVE ALL REAR END COMPONENTS

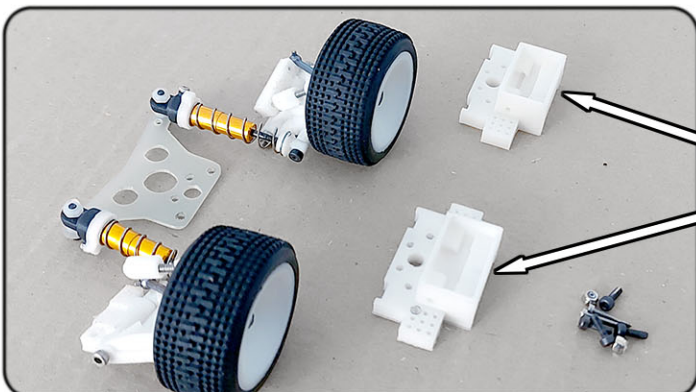

REPLACE REAR BULKHEAD WITH NEW BULKHEAD INCLUDED IN CONVERSION KIT



**ATTACH REAR END COMPONENTS TO MAIN GOLD CHASSIS PART
*USE M2x5MM COUNTERSUNK SCREWS FOR REAR OF A-ARM MOUNTS (INCLUDED)**

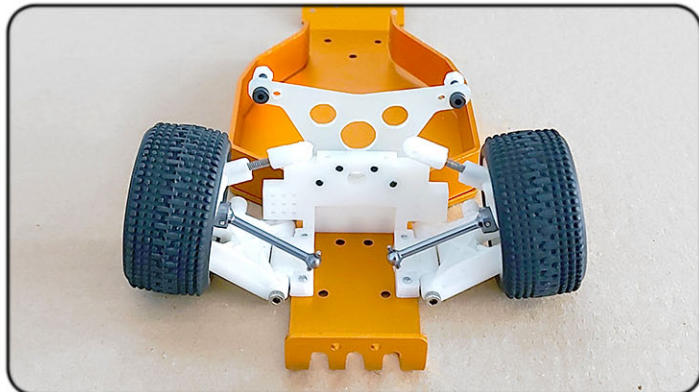

REMOVE REAR SHOCKS

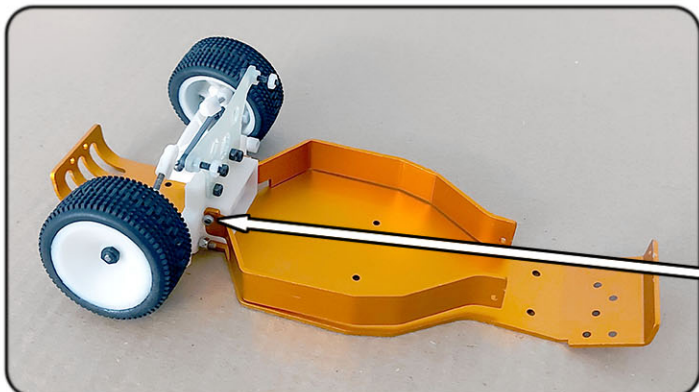

ATTACH GOLD SIDE PIECES TO REAR BULKHEAD WITH M2x10MM SCREWS

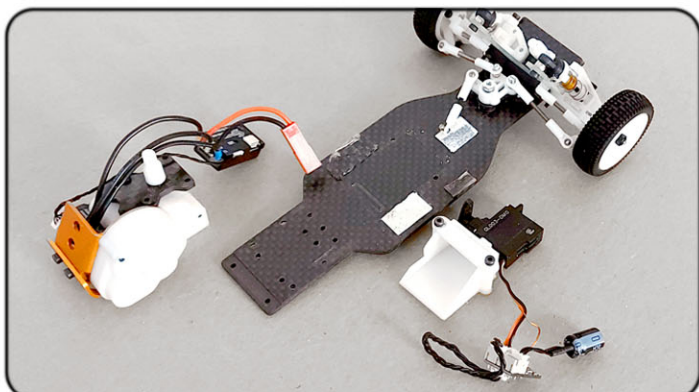

REMOVE ALL ELECTRONIC COMPONENTS FROM CHASSIS

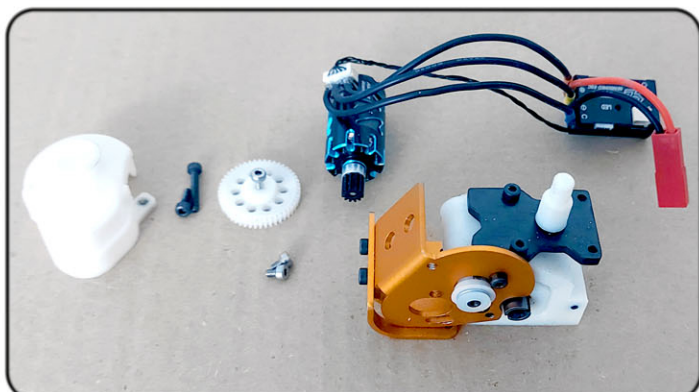

**REMOVE GEAR COVER, SPUR GEAR & MOTOR FROM REAR END
(PHOTO SHOWS OPTIONAL GEARBOX BRACE- NOT INCLUDED)**

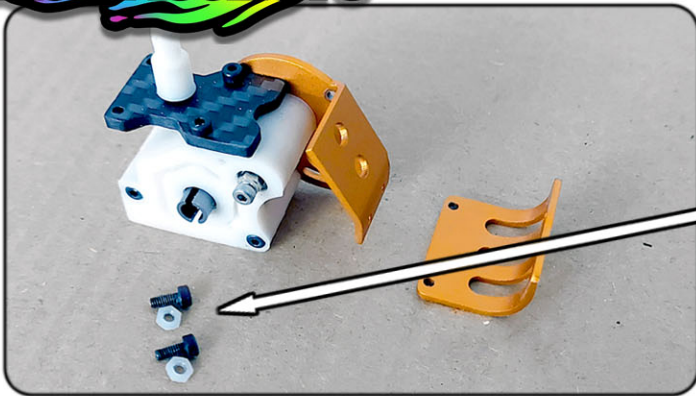

REMOVE REAR MOTOR GUARD. USE THESE M2x6MM SCREWS AND NYLON NUTS WHEN ATTACHING MOTOR PLATE TO NEW CHASSIS

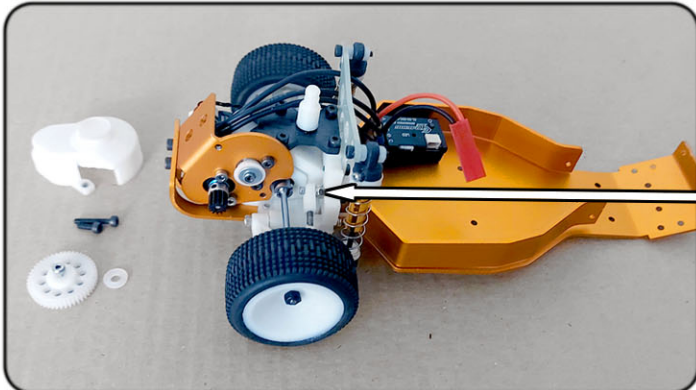

RE-ATTACH GEARBOX & MOTOR PLATE TO NEW CHASSIS. USE M2x6MM SCREWS TO FIX GEARBOX BRACE TO REAR BULKHEAD. RE-ATTACH CAMBER LINKS TO REAR BULKHEAD

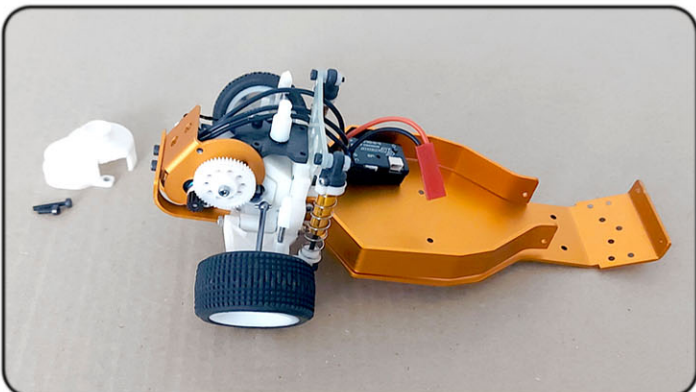

SET GEAR MESH AND RE-ATTACH SPUR GEAR (SEE MAIN USER MANUAL FOR GEAR MESH SETTING)

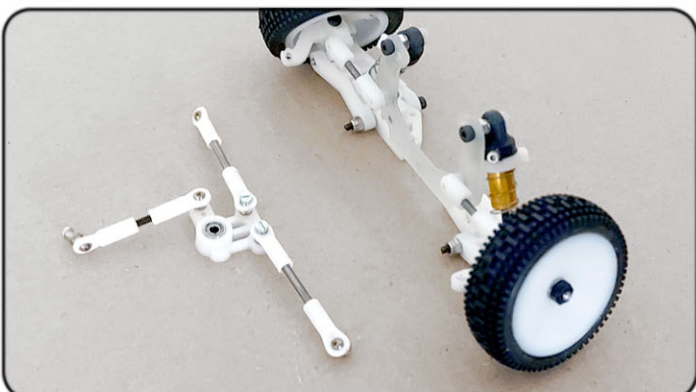

REMOVE ALL FRONT COMPONENTS FROM CARBON CHASSIS & NOSE PIECE. DETATCH STEERING ASSEMBLY

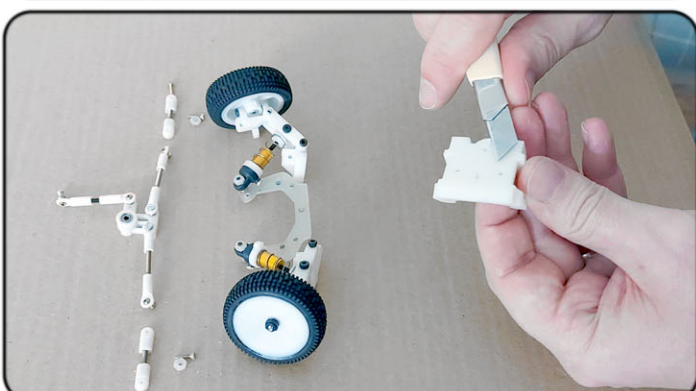

REMOVE FRONT CAMBER LINKS. TRIM OR SAND RAISED BUMPS FROM BOTTOM OF NEW CHASSIS BRACE

(THESE ARE RESIDUAL SUPPORT MATERIAL FROM 3D PRINTING PROCESS)



REMOVE STEERING BEARINGS & REPLACE BELLCRANK WITH NEW BELLCRANK INCLUDED

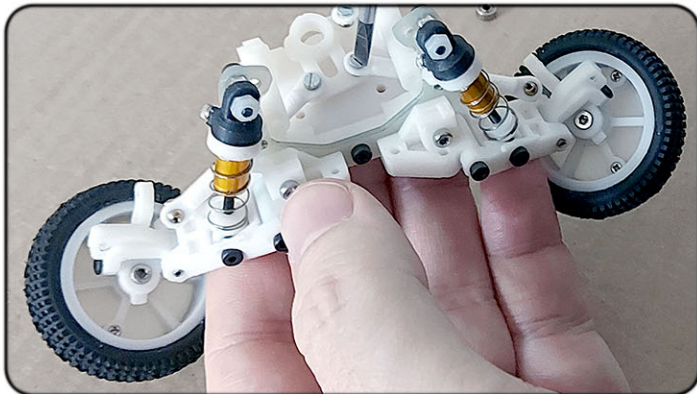

ATTACH FRONT END TO NEW CHASSIS BRACE WITH M2x12MM SCREWS (SIDES) AND M2x6MM IN CENTRE OF SHOCK TOWER

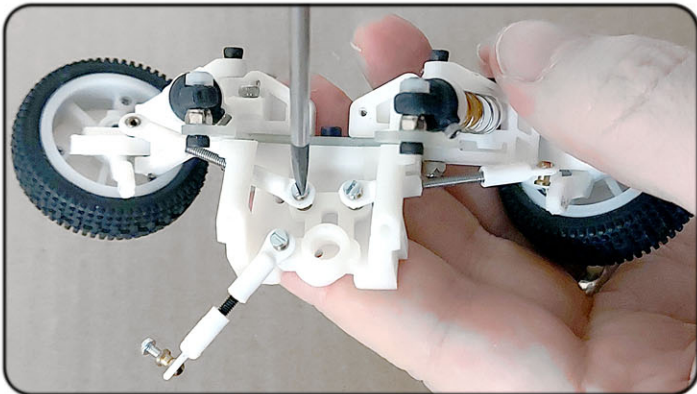

PUSH STEERING LINK THROUGH ONE SIDE, AND THEN THE OTHER SIDE & ATTACH TO BELLCRANK. DO NOT OVERTIGHTEN!

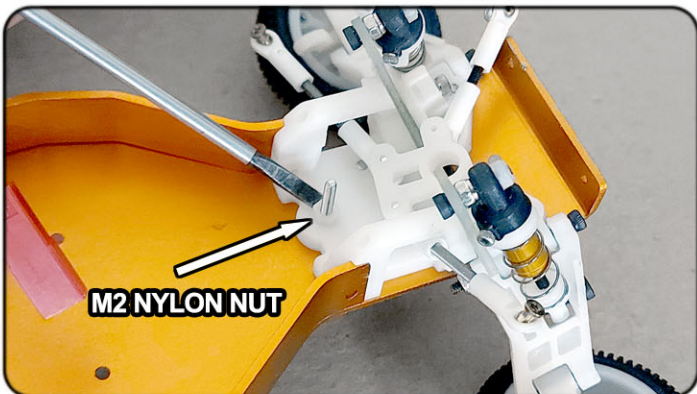

USE M2x14MM COUNTERSUNK SCREW FROM CARBON CHASSIS BRACE TO ATTACH NEW CHASSIS BRACE. ADD M2 NYLON NUT



INSERT M2x6MM SCREWS TO ATTACH CHASSIS SIDES TO NEW CHASSIS BRACE. ATTACH STEERING BELLCRANK WITH BEARINGS INSERTED



REPLACE M2x14MM GRUB SCREWS WITH M2x10MM GRUB SCREWS (INCLUDED) & RE-ATTACH FRONT CAMBER LINKS. NEW LINKS SHOULD BE APPROX 22.5MM TOTAL LENGTH (2.8MM GAP IN CENTRE)

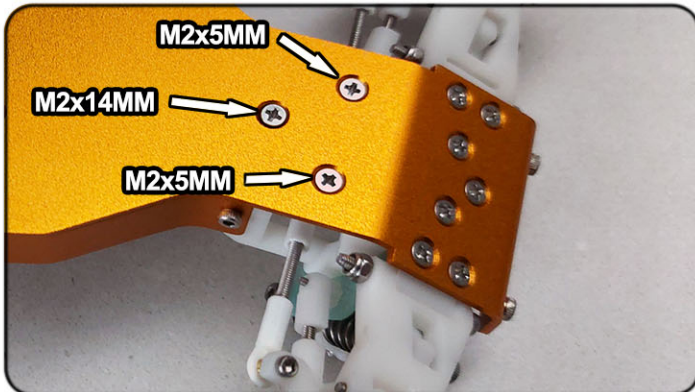

REPLACE M2x6MM COUNTERSUNK SCREWS WITH M2x5MM SCREWS (INCLUDED)

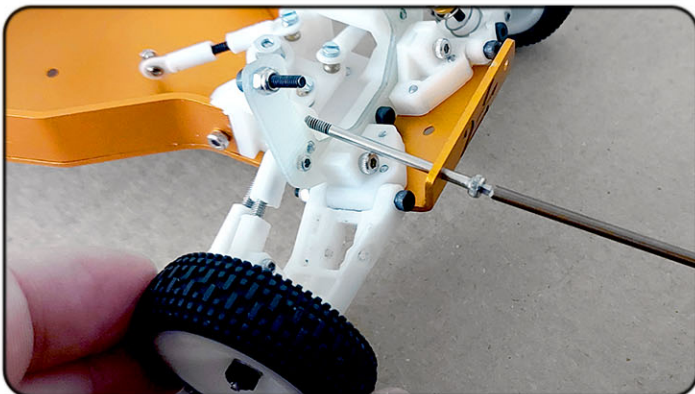

CONNECT CHASSIS NOSE TO NEW CHASSIS BRACE WITH M2x30MM SCREWS (INCLUDED)

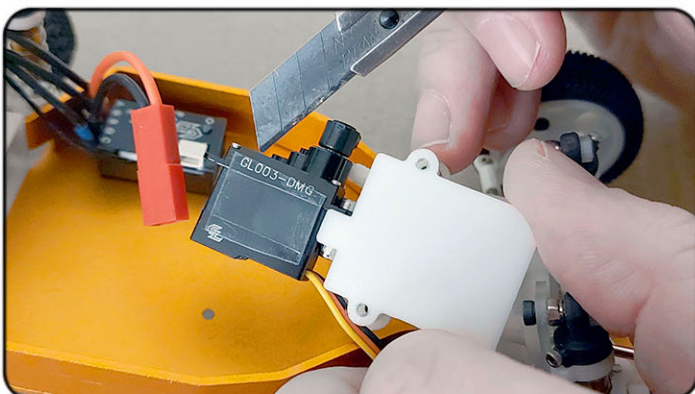

APPLY SERVO TAPE/DOUBLE SIDED TAPE TO BOTTOM OF SERVO

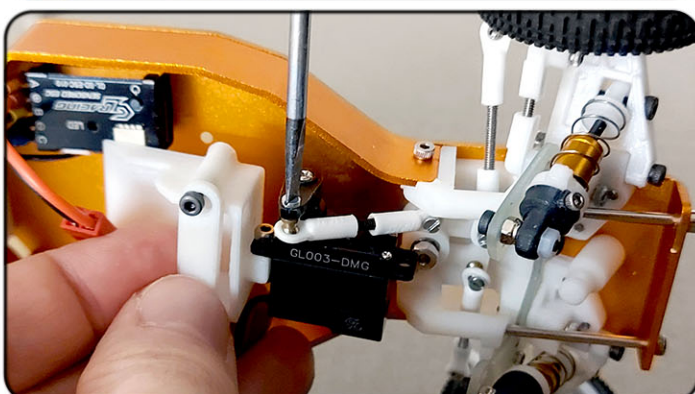

RE-ATTACH STEERING ROD & SERVO HORN. USE ORIGINAL M2x6MM COUNTERSUNK SCREWS TO ATTACH BATTERY CUP-SERVO ASSEMBLY TO CHASSIS.

CONGRATULATIONS! YOU'VE FINISHED THE GOLD ALUMINUM CHASSIS CONVERSION. THE BODY SHELL CAN BE ATTACHED WITH EITHER BODY CLIPS OR VELCRO (HOOK AND LOOP).

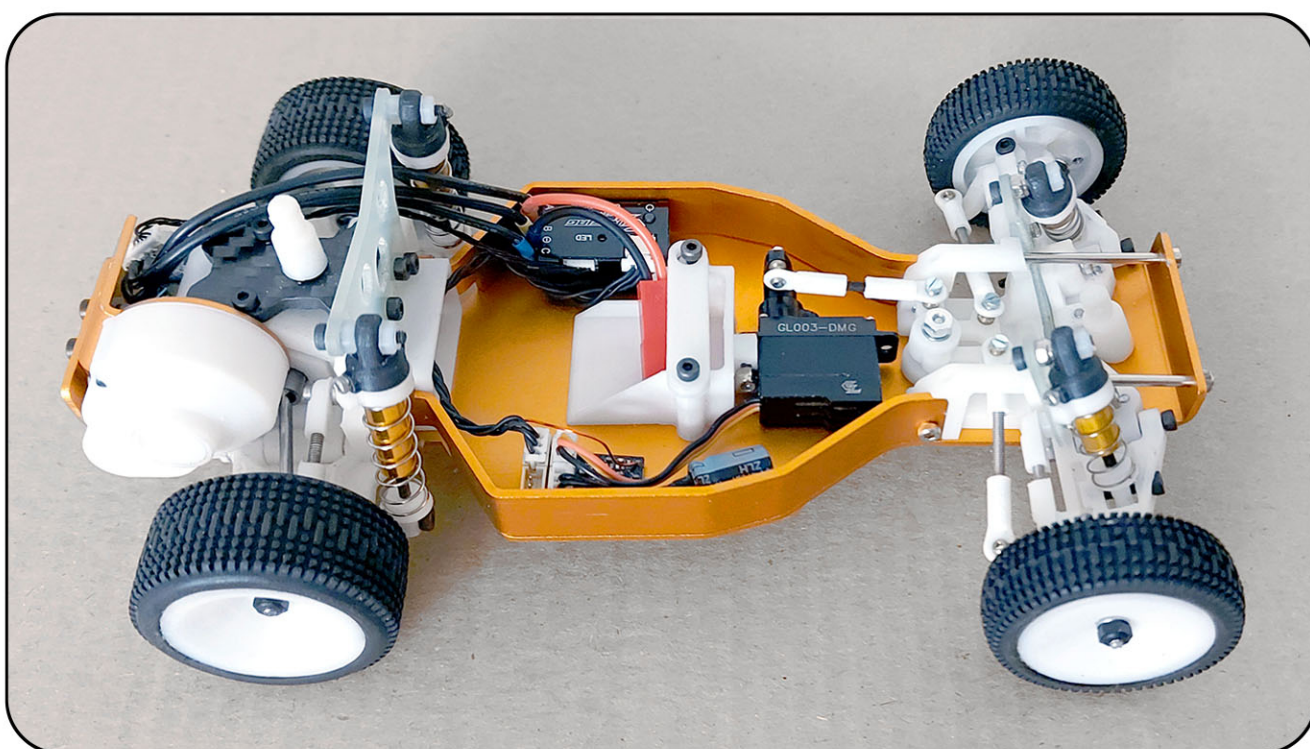
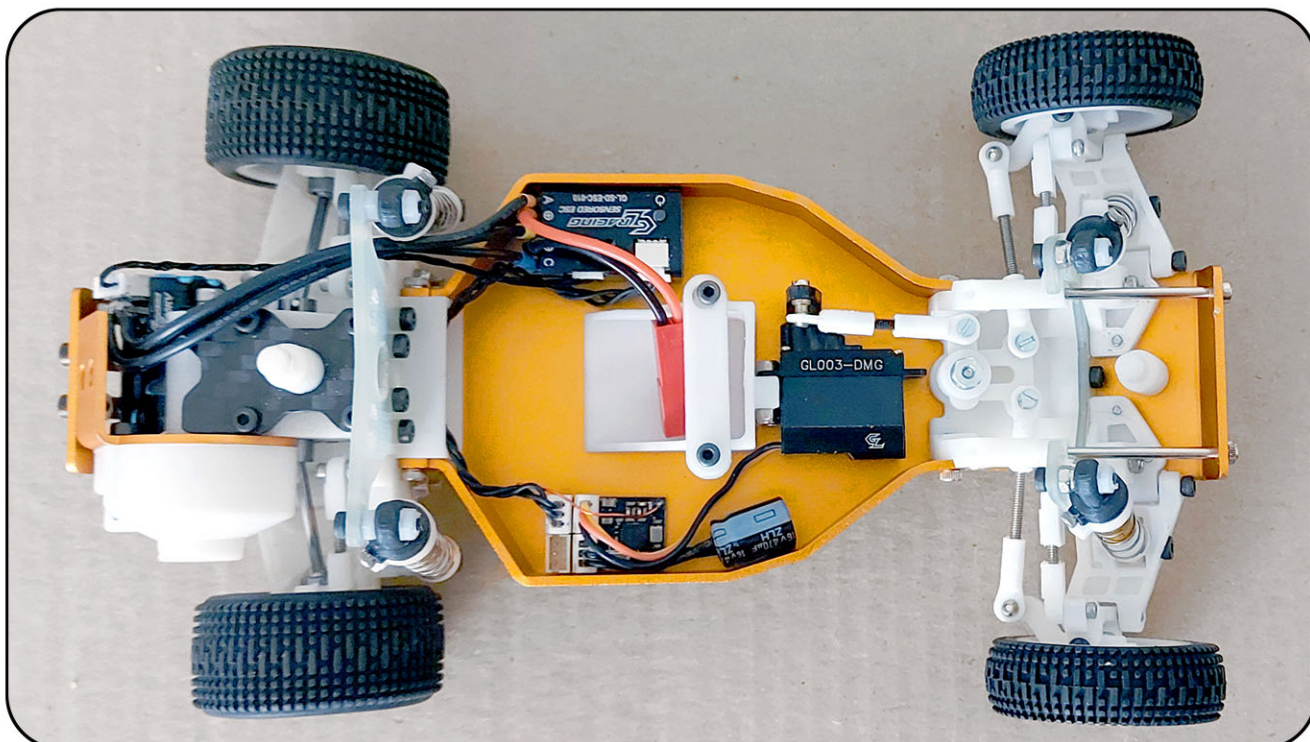

WE HOPE YOU ENJOY YOUR BUGGY AND PLEASE LET US KNOW IF YOU HAVE ANY QUESTIONS OR COMMENTS- HELLO.NRCPROJECTS@GMAIL.COM